

14 Human Heredity

**Big
idea**

Information and Heredity

Q: How can we use genetics to study human inheritance?



BIOLOGY.com

Search

Chapter 14

GO

Flash Cards

CHAPTER MYSTERY

INSIDE:

- 14.1 Human Chromosomes
- 14.2 Human Genetic Disorders
- 14.3 Studying the Human Genome

THE CROOKED CELL

When Ava visited her Uncle Eli in the hospital, he appeared tired and pale. He complained of sharp pains in his bones. “I’ve got sickle cell disease,” Uncle Eli explained, short of breath. “I just hope it doesn’t run in your side of the family.”

That evening, Ava searched the Internet for information about her uncle’s disease. She saw photos of red blood cells shaped like the letter C—a far cry from the healthy, round blood cells of a normal individual. Ava learned that these sickle-shaped cells are rigid and sticky. In blood vessels, they form clumps that can block blood flow and even cause organ damage. “Am I at risk?” Ava wondered. To find out, she would need to investigate her family history—and her own cells. As you read this chapter, look for clues that would help Ava discover whether she might carry sickle cell trait. Then, solve the mystery.

Never Stop Exploring Your World.

Finding out about Ava’s risk of sickle cell disease is only the beginning. Take a video field trip with the ecogeeks of Untamed Science to see where the mystery leads.



One thing to notice about this group of students is that none of them looks alike. The diversity of traits among the human race stems from one microscopic molecule—DNA.

• Untamed Science Video • Chapter Mystery

14.1

Human Chromosomes

Key Questions

 **What is a karyotype?**

 **What patterns of inheritance do human traits follow?**

 **How can pedigrees be used to analyze human inheritance?**

Vocabulary

genome • karyotype • sex chromosome • autosome • sex-linked gene • pedigree

Taking Notes

Outline Before you read, make an outline of the major headings in the lesson. As you read, fill in main ideas and supporting details for each heading.

THINK ABOUT IT If you had to pick an ideal organism for the study of genetics, would you choose one that produced lots of offspring? How about one that was easy to grow in the lab? Would you select one with a short life span in order to do several crosses per month? How about all of the above? You certainly would not choose an organism that produced very few offspring, had a long life span, and could not be grown in a lab. Yet, when we study human genetics, this is exactly the sort of organism we deal with. Given all of these difficulties, it may seem a wonder that we know as much about human genetics as we do.

Karyotypes

 **What is a karyotype?**

What makes us human? We might try to answer that question by looking under the microscope to see what is inside a human cell. Not surprisingly, human cells look much like the cells of other animals. To find what makes us uniquely human, we have to look deeper, into the genetic instructions that build each new individual. To begin this undertaking,

we have to explore the human genome. A **genome** is the full set of genetic information that an organism carries in its DNA.

The study of any genome starts with chromosomes—those bundles of DNA and protein found in the nuclei of eukaryotic cells. To see human chromosomes clearly, cell biologists photograph cells in mitosis, when the chromosomes are fully condensed and easy to view. Scientists then cut out the chromosomes from the photographs and arrange them in a picture known as a **karyotype** (KAR ee uh typ).  A karyotype shows the complete diploid set of chromosomes grouped together in pairs, arranged in order of decreasing size.



FIGURE 14-1 A Human Karyotype

A typical human cell has 23 pairs of chromosomes. These chromosomes have been cut out of a photograph and arranged to form a karyotype.

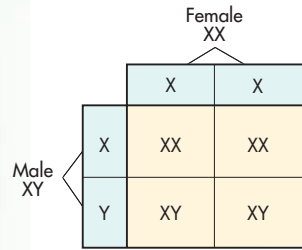

FIGURE 14-2 Sex Ratios Human egg cells contain a single X chromosome. Sperm cells contain either one X chromosome or one Y chromosome. **Interpret Tables** What does this Punnett square suggest about the sex ratio of the human population?

The karyotype in **Figure 14-1** is from a typical human cell, which contains 46 chromosomes, arranged in 23 pairs. Why do our chromosomes come in pairs? Remember that we begin life when a haploid sperm, carrying just 23 chromosomes, fertilizes a haploid egg, also with 23 chromosomes. The resulting diploid cell develops into a new individual and carries the full complement of 46 chromosomes—two sets of 23.

Sex Chromosomes Two of the 46 chromosomes in the human genome are known as **sex chromosomes**, because they determine an individual's sex. Females have two copies of the X chromosome. Males have one X chromosome and one Y chromosome. As you can see in **Figure 14-2**, this is the reason why males and females are born in a roughly 50 : 50 ratio. All human egg cells carry a single X chromosome (23,X). However, half of all sperm cells carry an X chromosome (23,X) and half carry a Y chromosome (23,Y). This ensures that just about half the zygotes will be males and half will be females.

More than 1200 genes are found on the X chromosome, some of which are shown in **Figure 14-3**. Note that the human Y chromosome is much smaller than the X chromosome and contains only about 140 genes, most of which are associated with male sex determination and sperm development.

Autosomal Chromosomes To distinguish them from the sex chromosomes, the remaining 44 human chromosomes are known as autosomal chromosomes, or **autosomes**. The complete human genome consists of 46 chromosomes, including 44 autosomes and 2 sex chromosomes. To quickly summarize the total number of chromosomes present in a human cell—both autosomes and sex chromosomes—biologists write 46,XX for females and 46,XY for males.

In Your Notebook Describe what makes up a human karyotype.

X Chromosome

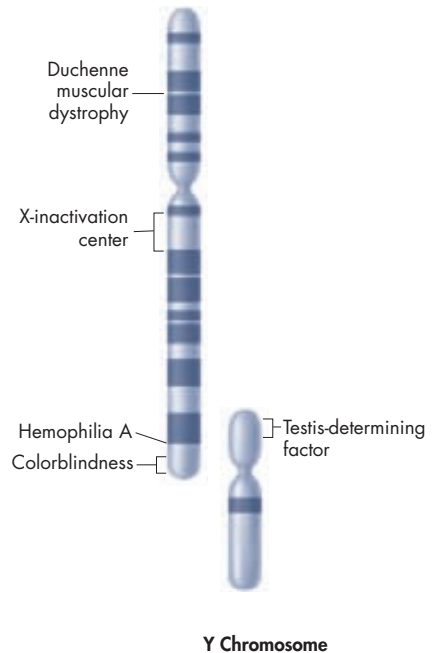

FIGURE 14-3 X and Y Chromosomes The human Y chromosome is smaller and carries fewer genes than the human X chromosome.



FIGURE 14-4 Recessive Alleles
Some of the recessive alleles of the *MC1R* gene cause red hair. An individual with red hair usually has two of these recessive alleles.

Transmission of Human Traits

What patterns of inheritance do human traits follow?

It has not been easy studying our species using traditional genetic techniques. Despite the difficulties, human genetics has progressed rapidly, especially in recent years, with the use of molecular techniques to study human DNA. What have these studies shown? Human genes follow the same Mendelian patterns of inheritance as the genes of other organisms.

Dominant and Recessive Alleles  Many human traits follow a pattern of simple dominance. For instance, a gene known as *MC1R* helps determine skin and hair color. Some of *MC1R*'s recessive alleles produce red hair. An individual with red hair usually has two of these recessive alleles, inheriting a copy from each parent. Dominant alleles for the *MC1R* gene help produce darker hair colors.

Another trait that displays simple dominance is the Rhesus, or Rh blood group. The allele for Rh factor comes in two forms: Rh⁺ and Rh⁻. Rh⁺ is dominant, so an individual with both alleles (Rh⁺/Rh⁻) is said to have Rh positive blood. Rh negative blood is found in individuals with two recessive alleles (Rh⁻/Rh⁻).

Codominant and Multiple Alleles  The alleles for many human genes display codominant inheritance. One example is the ABO blood group, determined by a gene with three alleles: I^A, I^B, and *i*. Alleles I^A and I^B are codominant. They produce molecules known as antigens on the surface of red blood cells. As Figure 14-5 shows, individuals with alleles I^A and I^B produce both A and B antigens, making them blood type AB. The *i* allele is recessive. Individuals with alleles I^AI^A or I^A*i* produce only the A antigen, making them blood type A. Those with I^BI^B or I^B*i* alleles are type B. Those homozygous for the *i* allele (*ii*) produce no antigen and are said to have blood type O. If a patient has AB-negative blood, it means the individual has I^A and I^B alleles from the ABO gene and two Rh⁻ alleles from the Rh gene.

FIGURE 14-5 Human Blood Groups

This table shows the relationship between genotype and phenotype for the ABO blood group. It also shows which blood types can safely be transfused into people with other blood types. **Apply Concepts** How can there be four different phenotypes even though there are six different genotypes?

Blood Groups				
Phenotype (Blood Type)	Genotype	Antigen on Red Blood Cell	Safe Transfusions	
			To	From
A	I ^A I ^A or I ^A <i>i</i>	A	A, AB	A, O
B	I ^B I ^B or I ^B <i>i</i>	B	B, AB	B, O
AB	I ^A I ^B	A and B	AB	A, B, AB, O
O	<i>ii</i>	None	A, B, AB, O	O

Sex-Linked Inheritance 🗝️ Because the X and Y chromosomes determine sex, the genes located on them show a pattern of inheritance called sex-linkage. A **sex-linked gene** is a gene located on a sex chromosome. As you might expect, genes on the Y chromosome are found only in males and are passed directly from father to son. Genes located on the X chromosome are found in both sexes, but the fact that men have just one X chromosome leads to some interesting consequences.

For example, humans have three genes responsible for color vision, all located on the X chromosome. In males, a defective allele for any of these genes results in colorblindness, an inability to distinguish certain colors. The most common form, red-green colorblindness, occurs in about 1 in 12 males. Among females, however, colorblindness affects only about 1 in 200. Why is there such a difference? In order for a recessive allele, like colorblindness, to be expressed in females, it must be present in two copies—one on each of the X chromosomes. This means that the recessive phenotype of a sex-linked genetic disorder tends to be much more common among males than among females.

MYSTERY CLUE

The presence of two sickle cell alleles is needed to produce sickle cell disease.

Males and females develop sickle cell disease in equal frequencies. What do these statements suggest about the location of the gene responsible for the disorder?

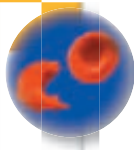

Quick Lab

GUIDED INQUIRY

How Is Colorblindness Transmitted?

1 Make a data table with the column headings Trial, Colors, Sex of Individual, and Number of X-Linked Alleles. Draw ten rows under the headings and fill in the numbers 1 through 10 in the Trial column. Label one plastic cup Mother and a second plastic cup Father.

2 The white beans represent X chromosomes. Use a black marker to make a dot on 1 white bean to represent the X-linked allele for colorblindness. Place this bean, plus 1 unmarked white bean, into the cup labeled Mother.

3 Mark a black dot on 1 more white bean. Place this bean, plus 1 red bean, into the cup labeled Father. The red bean represents a Y chromosome.



4 Close your eyes and pick one bean from each cup to represent how each parent contributes to a sex chromosome and a fertilized egg.

5 In your data table, record the color of each bean and the sex of an individual who would carry this pair of sex chromosomes. Also record how many X-linked alleles the individual has. Put the beans back in the cups they came from.

6 Determine whether the individual would have colorblindness.

7 Repeat steps 4 to 6 for a total of 10 pairs of beans.

Analyze and Conclude

1. **Draw Conclusions** How do human sex chromosomes keep the numbers of males and females roughly equal?

2. **Calculate** Calculate the class totals for each data column. How many females were colorblind? How many males? Explain these results. **MATH**

3. **Use Models** Evaluate your model. How accurately does it represent the transmission of colorblindness in a population? Why?



FIGURE 14–6 X-Chromosome Inactivation Female calico cats are tri-colored. The color of spots on their fur is controlled by a gene on the X chromosome. Spots are either orange or black, depending on which X chromosome is inactivated in different patches of their skin.

X-Chromosome Inactivation If just one X chromosome is enough for cells in males, how does the cell “adjust” to the extra X chromosome in female cells? The answer was discovered by the British geneticist Mary Lyon. In female cells, most of the genes in one of the X chromosomes are randomly switched off, forming a dense region in the nucleus known as a Barr body. Barr bodies are generally not found in males because their single X chromosome is still active.

The same process happens in other mammals. In cats, for example, a gene that controls the color of coat spots is located on the X chromosome. One X chromosome may have an allele for orange spots and the other X chromosome may have an allele for black spots. In cells in some parts of the body, one X chromosome is switched off. In other parts of the body, the other X chromosome is switched off. As a result, the cat’s fur has a mixture of orange and black spots, like those in **Figure 14–6**. Male cats, which have just one X chromosome, can have spots of only one color. Therefore, if the cat’s fur has three colors—white with orange and black spots, for example—you can almost be certain that the cat is female.

In Your Notebook Write three quiz questions about the transmission of human traits and answer them.

Human Pedigrees

How can pedigrees be used to analyze human inheritance?

Given the complexities of genetics, how would you go about determining whether a trait is caused by a dominant or recessive allele and whether the gene for that trait is autosomal or sex-linked? The answers, not surprisingly, can be found by applying Mendel’s basic principles of genetics.

To analyze the pattern of inheritance followed by a particular trait, you can use a chart that shows the relationships within a family. Such a chart is called a **pedigree**. A pedigree shows the presence or absence of a trait according to the relationships between parents, siblings, and offspring. It can be used for any species, not just humans.

The pedigree in **Figure 14–7** shows how one human trait—a white lock of hair just above the forehead—passes through three generations of a family. The allele for the white forelock trait is dominant. At the top of the chart is a grandfather who had the white forelock trait. Two of his three children inherited the trait. Three grandchildren have the trait, but two do not.

BUILD Vocabulary

WORD ORIGINS The word **pedigree** combines the Latin words *pedem*, meaning “foot,” and *gruem*, meaning “crane.” A crane is a long-legged waterbird. On old manuscripts, a forked sign resembling a crane’s footprint indicated a line of ancestral descent.

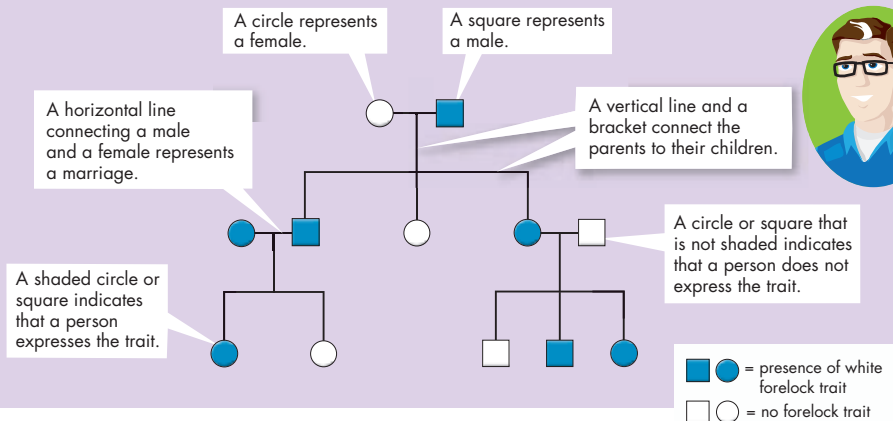

By analyzing a pedigree, we can often infer the genotypes of family members. For example, because the white forelock trait is dominant, all the family members in **Figure 14–7** lacking this trait must have homozygous recessive alleles. One of the grandfather's children lacks the white forelock trait, so the grandfather must be heterozygous for this trait.

With pedigree analysis, it is possible to apply the principles of Mendelian genetics to humans. **The information gained from pedigree analysis makes it possible to determine the nature of genes and alleles associated with inherited human traits.** Based on a pedigree, you can often determine if an allele for a trait is dominant or recessive, autosomal or sex-linked.

FIGURE 14–7 Pedigree Example

This diagram shows what the symbols in a pedigree represent.

Interpret Visuals What are the genotypes of both parents on the left in the second row? How do you know?

14.1 Assessment

Review Key Concepts

1. **a. Review** What are autosomes?
 - b. Explain** What determines whether a person is male or female?
 - c. Propose a Solution** How can you use karyotypes to identify a species?
2. **a. Review** Explain how sex-linked traits are inherited.
 - b. Predict** If a woman with type O blood and a man with type AB blood have children, what are the children's possible genotypes?

3. **a. Review** What does a pedigree show?
 - b. Infer** Why would the Y chromosome be unlikely to contain any of the genes that are absolutely necessary for survival?

VISUAL THINKING

4. Choose a family and a trait, such as facial dimples, that you can trace through three generations. Find out who in the family has had the trait and who has not. Then, draw a pedigree to represent the family history of the trait.

14.2

Human Genetic Disorders

Key Questions

 **How do small changes in DNA molecules affect human traits?**

 **What are the effects of errors in meiosis?**

Vocabulary

nondisjunction

Taking Notes

Two-Column Chart Before you read, make a two-column chart. In the first column, write three questions you have about genetic disorders. As you read, fill in answers to your questions in the second column. When you have finished, research the answers to your remaining questions.

THINK ABOUT IT Have you ever heard the expression “It runs in the family”? Relatives or friends might have said that about your smile or the shape of your ears, but what could it mean when they talk of diseases and disorders? What, exactly, is a genetic disorder?

From Molecule to Phenotype

 **How do small changes in DNA molecules affect human traits?**

We know that genes are made of DNA and that they interact with the environment to produce an individual organism’s characteristics, or phenotype. However, when a gene fails to work or works improperly, serious problems can result.

Molecular research techniques have shown us a direct link between genotype and phenotype. For example, the wax that sometimes builds up in our ear canals can be one of two forms: wet or dry. People of African and European ancestry are more likely to have wet earwax—the dominant form. Those of Asian or Native American ancestry most often have the dry form, which is recessive. A single DNA base in the gene for a membrane-transport protein is the culprit. A simple base change from guanine (G) to adenine (A) causes this protein to produce dry earwax instead of wet earwax.

The connection between molecule and trait, and between genotype and phenotype, is often that simple, and just as direct.  **Changes in a gene’s DNA sequence can change proteins by altering their amino acid sequences, which may directly affect one’s phenotype.** In other words, there is a molecular basis for genetic disorders.

Disorders Caused by Individual Genes Thousands of genetic disorders are caused by changes in individual genes. These changes often affect specific proteins associated with important cellular functions.

► **Sickle Cell Disease** This disorder is caused by a defective allele for beta-globin, one of two polypeptides in hemoglobin, the oxygen-carrying protein in red blood cells. The defective polypeptide makes hemoglobin a bit less soluble, causing hemoglobin molecules to stick together when the blood’s oxygen level decreases. The molecules clump into long fibers, forcing cells into a distinctive sickle shape, which gives the disorder its name.

Sickle-shaped cells are more rigid than normal red blood cells, and, therefore, they tend to get stuck in the capillaries—the narrowest blood vessels in the body. If the blood stops moving through the capillaries, damage to cells, tissues, and even organs can result.

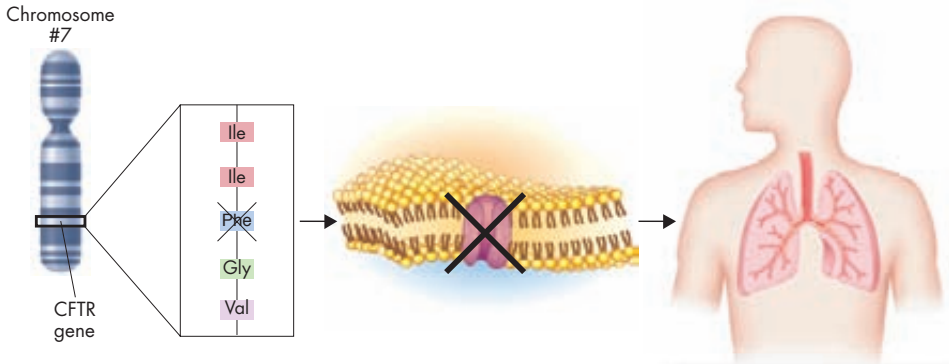

1 The most common allele that causes cystic fibrosis is missing 3 DNA bases. As a result, the amino acid phenylalanine is missing from the CFTR protein.

2 Normal CFTR is a chloride ion channel in cell membranes. Abnormal CFTR cannot transport ions across the cell membrane.

3 The cells in the person's airways are unable to transport chloride ions. As a result, the airways become clogged with a thick mucus.

► **Cystic Fibrosis** Known as CF for short, cystic fibrosis is most common among people of European ancestry. CF is caused by a genetic change almost as small as the earwax allele. Most cases result from the deletion of just three bases in the gene for a protein called cystic fibrosis transmembrane conductance regulator (CFTR). CFTR normally allows chloride ions (Cl^-) to pass across cell membranes. The loss of these bases removes a single amino acid—phenylalanine—from CFTR, causing the protein to fold improperly. The misfolded protein is then destroyed. With cell membranes unable to transport chloride ions, tissues throughout the body malfunction.

People with one normal copy of the CF allele are unaffected by CF, because they can produce enough CFTR to allow their cells to work properly. Two copies of the defective allele are needed to produce the disorder, which means the CF allele is recessive. Children with CF have serious digestive problems and produce thick, heavy mucus that clogs their lungs and breathing passageways.

► **Huntington's Disease** Huntington's disease is caused by a dominant allele for a protein found in brain cells. The allele for this disease contains a long string of bases in which the codon CAG—coding for the amino acid glutamine—repeats over and over again, more than 40 times. Despite intensive study, the reason why these long strings of glutamine cause disease is still not clear. The symptoms of Huntington's disease, namely mental deterioration and uncontrollable movements, usually do not appear until middle age. The greater the number of codon repeats, the earlier the disease appears, and the more severe are its symptoms.

FIGURE 14-8 Mutations Cause Cystic Fibrosis CF is usually caused by the deletion of three bases in the DNA of a single gene. As a result, the body does not produce normal CFTR, a protein needed to transport chloride ions. **Infer** Why isn't the cause of CF considered a frameshift mutation?

MYSTERY CLUE

Individuals with sickle cell disease have a different amino acid in one of their hemoglobin proteins than people without the disease. What could produce this change?



The Geography of Malaria

Malaria is a potentially fatal disease transmitted by mosquitoes. Its cause is a parasite that lives inside red blood cells. The upper map shows the parts of the world where malaria is common. The lower map shows regions where people have the sickle cell allele.

- Analyze Data** What is the relationship between the places where malaria and the sickle cell allele are found?
- Infer** In 1805, a Scottish explorer named Mungo Park led an expedition of European geographers to find the source of the Niger River in Africa. The journey began with a party of 45 Europeans. During the expedition, most of these men perished from malaria. Why do you think their native African guides survived?
- Form a Hypothesis** As the map shows, the sickle cell allele is not found in African populations that are native to southern Africa. Propose an explanation for this discrepancy.

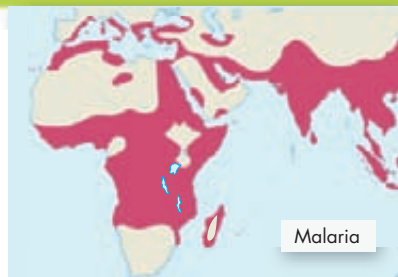

Genetic Advantages Disorders such as sickle cell disease and CF are still common in human populations. In the United States, the sickle cell allele is carried by approximately 1 person in 12 of African ancestry, and the CF allele is carried by roughly 1 person in 25 of European ancestry. Why are these alleles still around if they can be fatal for those who carry them? The answers may surprise you.

Most African Americans today are descended from populations that originally lived in west central Africa, where malaria is common. Malaria is a mosquito-borne infection caused by a parasite that lives inside red blood cells. Individuals with just one copy of the sickle cell allele are generally healthy and are also highly resistant to the parasite. This resistance gives them a great advantage against malaria, which even today claims more than a million lives every year.

More than 1000 years ago, the cities of medieval Europe were ravaged by epidemics of typhoid fever. Typhoid is caused by a bacterium that enters the body through cells in the digestive system. The protein produced by the CF allele helps block the entry of this bacterium. Individuals heterozygous for CF would have had an advantage when living in cities with poor sanitation and polluted water, and—because they also carried a normal allele—these individuals would not have suffered from cystic fibrosis.

BUILD Vocabulary

WORD ORIGINS The term *malaria* was coined in the mid-eighteenth century from the Italian phrase, *mala aria*, meaning “bad air.” It originally referred to the unpleasant odors caused by the release of marsh gases, to which the disease was initially attributed.

Chromosomal Disorders

🔑 What are the effects of errors in meiosis?

Most of the time, the process of meiosis works perfectly and each human gamete gets exactly 23 chromosomes. Every now and then, however, something goes wrong. The most common error in meiosis occurs when homologous chromosomes fail to separate. This mistake is known as **nondisjunction**, which means “not coming apart.”

Figure 14–9 illustrates the process.

🔑 If nondisjunction occurs during meiosis, gametes with an abnormal number of chromosomes may result, leading to a disorder of chromosome numbers. For example, if two copies of an autosomal chromosome fail to separate during meiosis, an individual may be born with three copies of that chromosome. This condition is known as a trisomy, meaning “three bodies.” The most common form of trisomy, involving three copies of chromosome 21, is Down syndrome, which is often characterized by mild to severe mental retardation and a high frequency of certain birth defects.

Nondisjunction of the X chromosomes can lead to a disorder known as Turner’s syndrome. A female with Turner’s syndrome usually inherits only one X chromosome. Women with Turner’s syndrome are sterile, which means that they are unable to reproduce. Their sex organs do not develop properly at puberty.

In males, nondisjunction may cause Klinefelter’s syndrome, resulting from the inheritance of an extra X chromosome, which interferes with meiosis and usually prevents these individuals from reproducing. There have been no reported instances of babies being born without an X chromosome, indicating that this chromosome contains genes that are vital for the survival and development of the embryo.

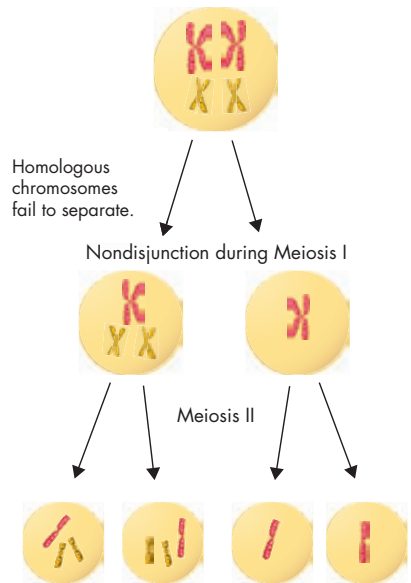

FIGURE 14–9 Nondisjunction This failure of meiosis causes gametes to have an abnormal number of chromosomes. **Apply Concepts** Which phase of meiosis is shown in the first cell?

14.2 Assessment

Review Key Concepts 🔑

- a. Review** How can a small change in a person’s DNA cause a genetic disorder?
b. Infer How do genetic disorders such as CF support the theory of evolution?
- a. Review** Describe two sex chromosome disorders.
b. Apply Concepts How does nondisjunction cause chromosomal disorders?

WRITE ABOUT SCIENCE

Description

- Write a paragraph explaining the process of nondisjunction. (*Hint:* To organize your writing, create a flowchart that shows the steps in the process.)



Biology & Society

Are Laws Protecting Genetic Privacy Necessary?

The rapid development of new tools and techniques to analyze DNA makes it possible to test for alleles related to thousands of medical conditions. In theory, the results of genetic testing should benefit everyone. Accurate genetic data helps physicians select the proper treatments for patients. It may allow people with genes that place them at risk of certain conditions to minimize those risks.

At issue, however, is individual privacy. Once a test is done, who has access to the data, and how can they use it? Could employers refuse to hire people who might drive up their medical costs? Might insurance companies refuse to renew the policies of individuals with genes for certain disorders? These are not hypothetical questions. In 2005, managers of a professional basketball team asked one of its players to be tested for a gene linked to heart ailments. When he refused, they traded the player to another team. Dr. Francis Collins, director of the National Human Genome Research Institute, worries that “the public is afraid of taking advantage of genetic testing.” Is he correct? Should genetic data be protected by law, or should it be open to public view?

The Viewpoints

Genetic Privacy Does Not Need Legal Protection

Other laws already protect individuals from discrimination on the basis of medical disability. Employers and insurance companies are nonetheless allowed to ask individuals if they smoke, use alcohol, or have a history of medical problems. Having this information allows employers to make intelligent choices about whom to hire. It also helps insurance companies maintain lower rates for their healthiest clients. Free access to genetic data should be a public right.



Many commercial laboratories test human DNA for genetic disorders.

Genetic Privacy Should Be Protected by Law

The Genetic Information Nondiscrimination Act (GINA) went into effect in 2009, and it provides important protections to personal privacy. Individuals may not take advantage of today’s advances in genetic medicine if they fear their personal information might be used to deny them employment or insurance. We need such laws to realize the full benefits of modern medicine and to protect otherwise healthy individuals from genetic discrimination.

Research and Decide

- 1. Analyze the Viewpoints** To make an informed decision, learn more about genetic testing by consulting library or Internet resources. Then, list the key arguments expressed by the proponents and critics of both points of view. Find out if laws preventing genetic discrimination have been proposed or passed in your state.
- 2. Form an Opinion** Should access and use of genetic data be regulated? Weigh both sides of the issue. Who will benefit from the sharing of genetic data? Will anyone suffer? Do some arguments outweigh others? If so, which ones? Explain your answers.

14.3

Studying the Human Genome

THINK ABOUT IT Just a few decades ago, computers were gigantic machines found only in laboratories and universities. Today, many of us carry small, powerful computers to school and work every day. Decades ago, the human genome was unknown. Today, we can see our entire genome on the Internet. How long will it be before having a copy of your own genome is as ordinary as carrying a cellphone in your pocket?



Manipulating DNA

🔑 *What techniques are used to study human DNA?*

Since discovering the genetic code, biologists have dreamed of a time when they could read the DNA sequences in the human genome. For a long time, it seemed impossible. DNA is a huge molecule—even the smallest human chromosome contains nearly 50 million base pairs. Manipulating such large molecules is extremely difficult. In the late 1960s, however, scientists found they could use natural enzymes in DNA analysis. From this discovery came many useful tools. **🔑** *By using tools that cut, separate, and then replicate DNA base by base, scientists can now read the base sequences in DNA from any cell.* Such techniques have revolutionized genetic studies of living organisms, including humans.

Cutting DNA Nucleic acids are chemically different from other macromolecules such as proteins and carbohydrates. This difference makes DNA relatively easy to extract from cells and tissues. However, DNA molecules from most organisms are much too large to be analyzed, so they must first be cut into smaller pieces. Many bacteria produce enzymes that do exactly that. Known as **restriction enzymes**, these highly specific substances cut even the largest DNA molecule into precise pieces, called restriction fragments, that are several hundred bases in length. Of the hundreds of known restriction enzymes, each cuts DNA at a different sequence of nucleotides.

In Your Notebook *Make a flowchart that shows the processes scientists use to analyze DNA.*

Key Questions

🔑 *What techniques are used to study human DNA?*

🔑 *What were the goals of the Human Genome Project, and what have we learned so far?*

Vocabulary

restriction enzyme
gel electrophoresis
bioinformatics
genomics

Taking Notes

Preview Visuals Before you read, look at **Figure 14–10**, and write down three questions you have about the figure. As you read, find answers to your questions.

Cutting DNA

A restriction enzyme is like a key that fits only one lock. The *EcoRI* restriction enzyme can only recognize the base sequence GAATTC. It cuts each strand of DNA between the G and A bases, leaving single-stranded overhangs with the sequence AATT. The overhangs are called “sticky ends” because they can bond, or “stick,” to a DNA fragment with the complementary base sequence.

Addition of restriction enzyme *EcoRI*

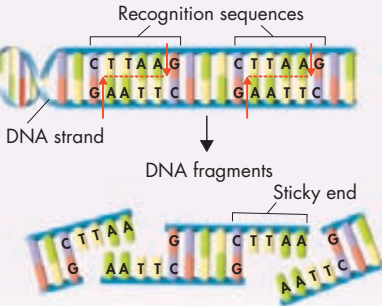

Separating DNA

Gel electrophoresis is used to separate DNA fragments. After being cut by restriction enzymes, the fragments are put into wells on a gel that is similar to a slice of gelatin. An electric voltage moves them across the gel. Shorter fragments move faster than longer fragments. Within an hour or two, the fragments all separate, each appearing as a band on the gel.

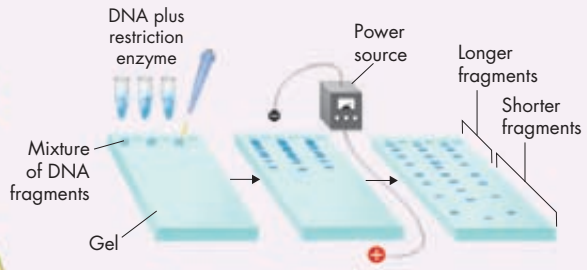

VISUAL SUMMARY

HOW SCIENTISTS MANIPULATE DNA

FIGURE 14-10 By using tools that cut, separate, and replicate DNA, scientists can read the base sequences in DNA from any cell. Knowing the sequence of an organism’s DNA allows us to study specific genes.

Separating DNA Once DNA has been cut by restriction enzymes, scientists can use a technique known as **gel electrophoresis** to separate and analyze the differently sized fragments. **Figure 14-10** illustrates this simple, yet effective, method. A mixture of DNA fragments is placed at one end of a porous gel. When an electric voltage is applied to the gel, DNA molecules—which are negatively charged—move toward the positive end of the gel. The smaller the DNA fragment, the faster and farther it moves. The result is a pattern of bands based on fragment size. Specific stains that bind to DNA make these bands visible. Researchers can then remove individual restriction fragments from the gel and study them further.

Reading DNA After the DNA fragments have been separated, researchers use a clever chemical “trick” to read, or sequence, them. The single-stranded DNA fragments are placed in a test tube containing DNA polymerase—the enzyme that copies DNA—along with the four nucleotide bases, A, T, G, and C. As the enzyme goes to work, it uses the unknown strand as a template to make one new DNA strand after another. The tricky part is that researchers also add a small number of bases that have a chemical dye attached. Each time a dye-labeled base is added to a new DNA strand, the synthesis of that strand stops. When DNA synthesis is completed, the result is a series of color-coded DNA fragments of different lengths. Researchers can then separate these fragments, often by gel electrophoresis. The order of colored bands on the gel tells the exact sequence of bases in the DNA. The entire process can be automated and controlled by computers, so that DNA sequencing machines can read thousands of bases in a matter of seconds.

Reading DNA

A small proportion of dye-labeled nucleotides are used to make a complementary DNA strand. Each time a labeled nucleotide is added to the strand, DNA replication stops. Because each base was labeled with a different color, the result is color-coded DNA fragments of different lengths. When gel electrophoresis is used to separate the fragments, scientists can “read” the DNA sequence directly from the gel.

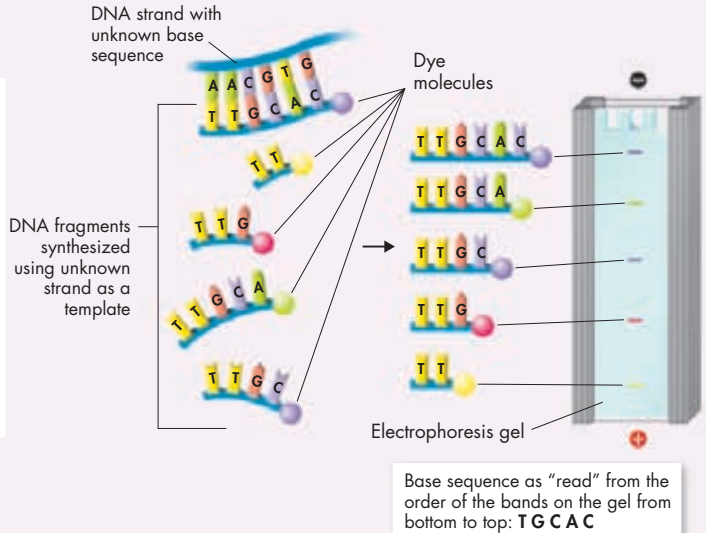

Quick Lab

GUIDED INQUIRY

Modeling Restriction Enzymes

- 1 Write a 50-base, double-stranded DNA sequence using the bases A, C, G, and T in random order. Include each sequence shown below at least once in the sequence you write.
- 2 Make three copies of your double-stranded sequence on three different-colored strips of paper.
- 3 Use the drawings below to see how the restriction enzyme *EcoRI* would cut your DNA sequence. Use scissors to cut one copy of the sequence as *EcoRI* would.

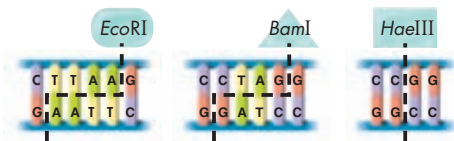

- 4 Use the procedure in Step 3 to cut apart another copy of your sequence as the restriction enzyme *BamI* would. Then, cut the third copy as the restriction enzyme *HaeIII* would.
- 5 Tape the single-stranded end of one of your DNA fragments to a complementary, single-stranded end of a classmate’s fragment. This will form a single, double-stranded DNA molecule.

Analyze and Conclude

1. **Observe** Which restriction enzyme produced the most pieces? The fewest pieces?
2. **Evaluate** How well did your model represent the actual process of using restriction enzymes to cut DNA? (*Hint*: Contrast the length of your model DNA sequence to the actual length of a DNA molecule.)

The Human Genome Project

🔑 What were the goals of the Human Genome Project, and what have we learned so far?

In 1990, the United States, along with several other countries, launched the Human Genome Project. **🔑 The Human Genome Project** was a 13-year, international effort with the main goals of sequencing all 3 billion base pairs of human DNA and identifying all human genes. Other important goals included sequencing the genomes of model organisms to interpret human DNA, developing technology to support the research, exploring gene functions, studying human variation, and training future scientists.

DNA sequencing was at the center of the Human Genome Project. However, the basic sequencing method you saw earlier can analyze only a few hundred nucleotides at a time. How, then, can the huge amount of DNA in the human genome be sequenced quickly? First, researchers must break up the entire genome into manageable pieces. By determining the base sequences in widely separated regions of a DNA strand, they can use the regions as markers, not unlike the mile markers along a road that is thousands of miles long. The markers make it possible for researchers to locate and return to specific locations in the DNA.

Sequencing and Identifying Genes Once researchers have marked the DNA strands, they can use the technique of “shotgun sequencing.” This rapid sequencing method involves cutting DNA into random fragments, then determining the base sequence in each fragment. Computer programs take the sequencing data, find areas of overlap between fragments, and put the fragments together by linking the overlapping areas. The computers then align these fragments relative to the known markers on each chromosome, as shown in **Figure 14–11**. The entire process is like putting a jigsaw puzzle together, but instead of matching shapes, the computer matches DNA base sequences.

Reading the DNA sequence of a genome is not the same as understanding it. Much of today’s research explores the vast amount of data from the Human Genome Project to look for genes and the DNA sequences that control them. By locating sequences known to be promoters—binding sites for RNA polymerase—scientists can identify many genes. Shortly after a promoter, there is usually an area called an open reading frame, which is a sequence of DNA bases that will produce an mRNA sequence. Other sites that help to identify genes are the sequences that separate introns from exons, and stop codons located at the ends of open reading frames. **Figure 14–12** shows these sites on a typical gene.

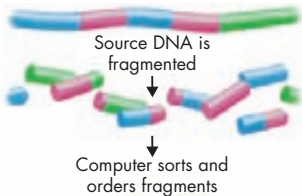

Overlapping sequences are matched and aligned to determine the complete DNA sequence.

FIGURE 14–11 Shotgun Sequencing This method rapidly sorts DNA fragments by overlapping base sequences.

```
GGGGCTGAGAGG7GCTTGGGGGGCCAGGACGAGACTGGGCAATGCAAGCTCCCAACCTGCCAC
CCCCAGATCTCTGGCCACCCCAACCCAGATCAACAAGGATGAGTGTCTGGTGGCTCTGTGGAGGCTTC
```

```
TTCTGCTCTTAGAGAGG7GGGAACTAGGACAGCCAGAGGGAGGAAAGGCTCTCTCCATCCCAAT
TCCGACCCCCACACTTGGCCACTCATCGGGGACTTCTGGGACCTCGGGAGCTGGGAGACAGGGGTCC
TGGGACAGGGGTCCGGGACAGGGTCTGGGACAGGGTGTGAGGACAGGGTCCCGGAGGACAGGGG
TGTGGGACAGGGTCCCGGAGCAGGGTGTGGGACAGGGTGTGGGACAGGGTGTGGGACAGGGT
```

```
GGGTTGGGACAGGGTGTGGGACAGGGTGTGGGACAGGGTGTGGGACAGGGTGTGGGACAGGGT
GGGTTGGGACAGGGTGTGGGACAGGGTGTGGGACAGGGTGTGGGACAGGGTGTGGGACAGGGT
ACACAGCGGAAAGGAGGCGGCTCCAGCTCCAGCTCTCTGGTCTAATGTGAAAGTGGCCAGGT
GAGGCTTCTCTCTGGGACATTTGGCCCACTGTGAGCAGGACAGGTGTGGCACCAGGGGCC
```

```
GGGTTGGGACAGGGTGTGGGACAGGGTGTGGGACAGGGTGTGGGACAGGGTGTGGGACAGGGT
ACCCGACACAGGAAATGGATTTGGACTTCAACCCCGGACATCTCCGACCCCTCCACCTCC
CAGGCTCATAGGGCAGCGGCTAGGGTGTGACAGGTAAGGAGGAGTGGGCTCGAATATAAAGCAG
CGGGGCCACAGCTCTCAGCCTCAGAGAGGAGGATCGATCAAGAGGCCATCAGAGGCTCTTTTC
CAAGGGCTTGGTTCAGGTTGGGCTCAGGGTTCAGGGTGTGGGACAGGGTCCCGGAGGACAGGG
GGGAGAGCTGGTGGGTTGGGACAGGGTGTGGGACAGGGTGTGGGACAGGGTGTGGGACAGGGT
CTCAGCCTGCTCAGCGCGCTGTGACATCATCTGCTCTCTGGGCTGGGAGGAGGAGGAGGAGG
TCTGCGCTCCCTGGGCGCTGGGCTCTGGGACTTGCACCGGCGGCTTTTGTGAAACAGCAGCC
TSTGGGCTCAGCTTSTGGGAGGCTCTCTCTAGTGTGGGAGGAGGAGGAGGAGGAGGAGGAGGAGG
AGACCCCGGGGGAGGAGGAGGAGGAGGAGGAGGAGGAGGAGGAGGAGGAGGAGGAGGAGGAGGAGG
CCACCCCTCTCTGGGCTCCAGCCCTGATGGGCGAGGGGAGGAGGAGGAGGAGGAGGAGGAGGAGG
GAGTGGGAGGAGGAGGAGGAGGAGGAGGAGGAGGAGGAGGAGGAGGAGGAGGAGGAGGAGGAGG
GSTCAGGAGGAGGAGGAGGAGGAGGAGGAGGAGGAGGAGGAGGAGGAGGAGGAGGAGGAGGAGG
CAGTCAAGGAGGAGGAGGAGGAGGAGGAGGAGGAGGAGGAGGAGGAGGAGGAGGAGGAGGAGG
TSTGGGCTCAGCTTSTGGGAGGAGGAGGAGGAGGAGGAGGAGGAGGAGGAGGAGGAGGAGGAGG
CTCTCTCTCTCTGGGCTCAGGGTGTGGGACAGGGTGTGGGACAGGGTGTGGGACAGGGTGTGGG
AGATGAGGAGGAGGAGGAGGAGGAGGAGGAGGAGGAGGAGGAGGAGGAGGAGGAGGAGGAGG
TCTGGGAGGAGGAGGAGGAGGAGGAGGAGGAGGAGGAGGAGGAGGAGGAGGAGGAGGAGGAGG
CCGAGGAGGAGGAGGAGGAGGAGGAGGAGGAGGAGGAGGAGGAGGAGGAGGAGGAGGAGGAGG
ACTGGAGGAGGAGGAGGAGGAGGAGGAGGAGGAGGAGGAGGAGGAGGAGGAGGAGGAGGAGGAGG
GAGGAGGAGGAGGAGGAGGAGGAGGAGGAGGAGGAGGAGGAGGAGGAGGAGGAGGAGGAGGAGG
GGGCTTGGGAGGAGGAGGAGGAGGAGGAGGAGGAGGAGGAGGAGGAGGAGGAGGAGGAGGAGGAGG
GGGAGGAGGAGGAGGAGGAGGAGGAGGAGGAGGAGGAGGAGGAGGAGGAGGAGGAGGAGGAGGAGG
TSTGGCTCTCTGGGCTCAGGGTGTGGGACAGGGTGTGGGACAGGGTGTGGGACAGGGTGTGGG
GGGAGGAGGAGGAGGAGGAGGAGGAGGAGGAGGAGGAGGAGGAGGAGGAGGAGGAGGAGGAGG
TSTGGCTCTCTGGGCTCAGGGTGTGGGACAGGGTGTGGGACAGGGTGTGGGACAGGGTGTGGG
CAGCCCGGAGGAGGAGGAGGAGGAGGAGGAGGAGGAGGAGGAGGAGGAGGAGGAGGAGGAGGAGG
G
```

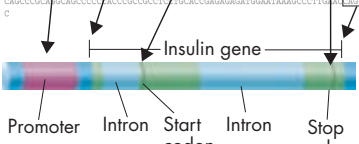

FIGURE 14–12 Locating a Gene A typical gene, such as that for insulin, has several DNA sequences that can serve as locators. These include the promoter, sequences between introns and exons, and start and stop codons.

Comparing Sequences If you were to compare the genomes of two unrelated individuals, you would find that most—but not all—of their DNA matches base-for-base with each other. On average, one base in 1200 will not match between two individuals. Biologists call these single base differences SNPs (pronounced “snips”), which stands for single nucleotide polymorphisms. Researchers have discovered that certain sets of closely linked SNPs occur together time and time again. These collections of linked SNPs are called haplotypes—short for haploid genotypes. To locate and identify as many haplotypes in the human population as possible, the International HapMap Project began in 2002. The aim of the project is to give scientists a rapid way to identify haplotypes associated with various diseases and conditions and to pave the way to more effective life-saving medical care in the future.

Sharing Data The Human Genome Project was completed in 2003. Copies of the human genome DNA sequence, and those of many other organisms, are now freely available on the Internet. Online computer access enables researchers and students to browse through databases of human DNA and study its sequence. More data from the human genome, and the genomes of other organisms, are added to these databases every day.

One of the key research areas of the Human Genome Project was a new field of study called **bioinformatics**. The root word, *informatics*, refers to the creation, development, and operation of databases and other computing tools to collect, organize, and interpret data. The prefix *bio-* refers to life sciences—specifically, molecular biology. Assembling the bits and pieces of the human genome would have been impossible without sophisticated computer programs that could recognize overlapping sequences and place them in the proper order, or immense databases where such information could be stored and retrieved. Without the tools of bioinformatics shown in **Figure 14–13**, the wealth of information gleaned from the Human Genome Project would hardly be useful. Bioinformatics also launched a more specialized field of study known as **genomics**—the study of whole genomes, including genes and their functions.

MYSTERY CLUE

Scientists can detect the sickle cell allele with a test for SNPs in the genes for the polypeptides that make up hemoglobin. What does this tell you about the sickle cell mutation?



FIGURE 14–13 Bioinformatics Bioinformatics is a new field that combines molecular biology with information science. It is critical to studying and understanding the human genome.

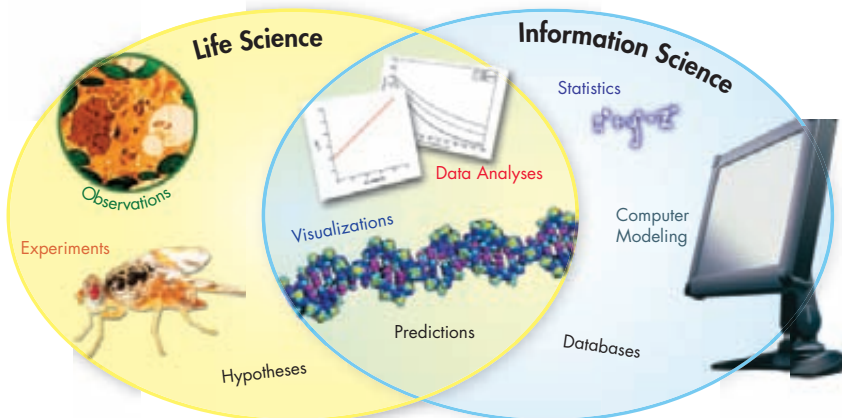



FIGURE 14-14 Announcements
The first details of the human genome appeared in two well-known scientific journals in February 2001.

FIGURE 14-15 Genome Size Comparisons The gene numbers in this table are not final. Some estimates include only protein-coding genes, while others include genes that code only for RNA. The discovery of small interfering RNAs (siRNAs) has complicated the definition of a gene.
Propose a Solution How could you find updated information on genome sizes?

What We Have Learned In June 2000, scientists announced that a working copy of the human genome was complete. The first details appeared in the February 2001 issues of the journals *Nature* and *Science*. The full reference sequence was completed in April 2003, marking the end of the Human Genome Project—two years ahead of the original schedule. Coincidentally, that was also the fiftieth anniversary of Watson and Crick’s publication of DNA structure that launched the era of molecular biology!

Besides finding that the human genome in its haploid form contains three billion nucleotide bases, the Human Genome Project uncovered a wealth of interesting, and sometimes surprising, information.

For instance, only about 2 percent of our genome encodes instructions for the synthesis of proteins, and many chromosomes contain large areas with very few genes. As much as half of our genome is made up of DNA sequences from viruses and other genetic elements within human chromosomes. During the project, investigators completed the genomes of several other organisms, including unicellular ones. They found that more than 40 percent of the proteins coded for by our genome have strong similarity to proteins in many of those organisms, including fruit flies, worms, and even yeast. **Figure 14-15** compares the human genome with these and other model organisms.

By any standard, the Human Genome Project has been a great scientific success. **🔗 The Human Genome Project pinpointed genes and associated particular sequences in those genes with numerous diseases and disorders. It also identified about three million locations where single-base DNA differences occur in humans.** This information may help us find DNA sequences associated with diabetes, cancer, and other health problems. The Human Genome Project also transferred important new technologies to the private sector, including agriculture and medicine. By doing so, the project catalyzed the U.S. biotechnology industry and fostered the development of new medical applications.

Size Comparison of Various Genomes

Organism	Genome Size (bases)	Estimated Genes
Human (<i>Homo sapiens</i>)	3.2 billion	25,000
Laboratory mouse (<i>M. musculus</i>)	2.5 billion	24,174
Fruit fly (<i>D. melanogaster</i>)	165.0 million	13,600
Mustard weed (<i>A. thaliana</i>)	120.0 million	25,498
Roundworm (<i>C. elegans</i>)	97.0 million	19,000
Yeast (<i>S. cerevisiae</i>)	12.1 million	6,294
Bacterium (<i>E. coli</i>)	4.6 million	4,288
Human immunodeficiency virus (HIV)	9749.0	9

New Questions Throughout its duration, the Human Genome Project worked to identify and address ethical, legal, and social issues surrounding the availability of human genome data and its powerful new technologies. The issues, including privacy, fairness in the use of and access to genomic information, medical issues, and commercialization, are complex. For example, who owns and controls genetic information? Is genetic privacy different from medical privacy? Who should have access to personal genetic information, and how will it be used? Right now, these questions are hypothetical, but they may not be for long. In May 2008, President George Bush signed into law the Genetic Information Nondiscrimination Act, which prohibits U.S. insurance companies and employers from discriminating on the basis of information derived from genetic tests. Other protective laws may soon follow.

What's Next? Many more sequencing projects are underway, helped along by powerful new technologies. You can expect an ever-growing database of information from microbial, animal, and plant genomes in the years ahead. Each of these will have its own mysteries to be explored, not to mention the fact that we still don't fully understand the functions of as many as 50 percent of the human genes thus far discovered.

The 1000 Genomes Project, launched in 2008, will study the genomes of 1000 people in an effort to produce a detailed catalogue of human variation. Data from the project will be used in future studies of development and disease, and the information may hold the key to successful research on new drugs and therapies to save human lives and preserve health.

Perhaps the most important challenge that lies ahead is to understand how all the “parts” of cells—genes, proteins, and many other molecules—work together to create complex living organisms. Future efforts may provide a deeper understanding of the molecular processes underlying life and may influence how we view our own place in the global ecosystem.

14.3 Assessment

Review Key Concepts

- a. Review** How do molecular biologists identify genes in sequences of DNA?
 - Use Analogies** How is shotgun sequencing similar to doing a jigsaw puzzle?
- a. Review** What is the Human Genome Project?
 - Form an Opinion** Judge the potential impact of the Human Genome Project on both scientific thought and society. How might the project be used to benefit humankind? What potential problems might it create?

WRITE ABOUT SCIENCE

Persuasion

- Scientists may one day be able to use genomics and molecular biology to alter a child's inherited traits. Under what circumstances, if any, should this ability be used? When should it not be used? Write a persuasive paragraph expressing your opinion. (*Hint:* Use specific examples of traits to support your ideas.)

Pre-Lab: Using DNA to Identify Human Remains

Problem How can pedigrees help scientists identify human remains?

Lab Manual Chapter 14 Lab

Skills Focus Analyze Data, Draw Conclusions

Connect to the Big idea The nucleus is not the only location in a cell where DNA can be found. DNA is also found in the mitochondria of cells. This mitochondrial DNA, or mtDNA, exists as small loops, rather than long strands. Unlike nuclear DNA, mtDNA is inherited only from the mother. Thus, except for mutations, the sequence of nucleotides in mtDNA remains constant over many generations.

Less than one percent of a cell's DNA is mtDNA, but in that percentage are many copies of the small mtDNA molecules. So when forensic scientists cannot collect a suitable sample of nuclear DNA, they look for mtDNA. Usable mtDNA can often be found even after a body decays or is burned. In this lab, you will explore how mtDNA was used to help confirm the identity of bones that scientists thought belonged to members of the Romanov family.

Background Questions

- Review** What is a pedigree?
- Explain** In a pedigree, what does a circle represent? What does a square represent?
- Infer** How do you know that mtDNA isn't sorted and recombined during meiosis?

Pre-Lab Questions

Preview the procedure in the lab manual.

- Infer** The tsar and tsarina had five children. Did all seven family members have the same mtDNA? Give a reason for your answer.
- Predict** To confirm that bones belonged to the tsar's children, which living relative would be more useful—a relative of the tsar or a relative of the tsarina? Why?



The Romanovs ruled Russia for 300 years until the Bolshevik Revolution of 1918 resulted in the execution of Tsar Nicholas II and his family.

- Infer** If two people have the same mtDNA, what can you infer about their biological relationship?

BIOLOGY.com

Search

Chapter 14

GO

Visit Chapter 14 online to test yourself on chapter content and to find activities to help you learn.

Untamed Science Video The Untamed Science crew identifies the chromosomes that carry genes for colorblindness.

Art in Motion View a short animation that explains nondisjunction.

Art Review Review your understanding of karyotypes with this drag-and-drop activity.

Interactive Art Learn all about pedigrees and how to make them with this animation.

Data Analysis Analyze the connection between type O blood and an increased susceptibility to cholera.

Tutor Tube Why do traits sometimes “skip a generation”? Tune in to the tutor to find out.

14 Study Guide

Big idea Information and Heredity

Humans have 23 pairs of chromosomes, including one pair of sex chromosomes, that follow the same patterns of Mendelian inheritance as do other organisms. Scientists study human heredity using karyotypes, pedigrees, and Punnett squares, but they also use the tools of molecular biology and bioinformatics to study DNA and gene expression. The Human Genome Project has revolutionized the study of human heredity.

14.1 Human Chromosomes

Key A karyotype shows the complete diploid set of chromosomes grouped together in pairs, arranged in order of decreasing size.

Key Human genes follow the same Mendelian patterns of inheritance as the genes of other organisms. Many human traits follow a pattern of simple dominance. The alleles for other human genes display codominant inheritance. Because the X and Y chromosomes determine sex, the genes located on them show a pattern of inheritance called sex-linkage.

Key The information gained from pedigree analysis makes it possible to determine the nature of genes and alleles associated with inherited human traits.

genome (392)

karyotype (392)

sex chromosome (393)

autosome (393)

sex-linked gene (395)

pedigree (396)

14.2 Human Genetic Disorders

Key Changes in a gene's DNA sequence can change proteins by altering their amino acid sequences, which may directly affect one's phenotype.

Key If nondisjunction occurs during meiosis, gametes with an abnormal number of chromosomes may result, leading to a disorder of chromosome numbers.

nondisjunction (401)

14.3 Studying the Human Genome

Key By using tools that cut, separate, and then replicate DNA base by base, scientists can now read the base sequences in DNA from any cell.

Key The Human Genome Project was a 13-year, international effort with the main goals of sequencing all 3 billion base pairs of human DNA and identifying all human genes.

Key The Human Genome Project pinpointed genes and associated particular sequences in those genes with numerous diseases and disorders. It also identified about three million locations where single-base DNA differences occur in humans.

restriction enzyme (403)

bioinformatics (407)

gel electrophoresis (404)

genomics (407)



Think Visually

Create a concept map using the following terms: nondisjunction, autosomes, sex chromosomes, Down syndrome, Turner's syndrome, and Klinefelter's syndrome.

14 Assessment

14.1 Human Chromosomes

Understand Key Concepts

1. A normal human diploid zygote contains
 - a. 23 chromosomes.
 - b. 46 chromosomes.
 - c. 44 chromosomes.
 - d. XXY chromosomes.
2. A chart that traces the inheritance of a trait in a family is called a(n)
 - a. pedigree.
 - b. karyotype.
 - c. genome.
 - d. autosome.
3. An example of a trait that is determined by multiple alleles is
 - a. cystic fibrosis.
 - b. ABO blood groups.
 - c. Down syndrome.
 - d. colorblindness.
4. What is the difference between autosomes and sex chromosomes?
5. Is it possible for a person with blood type alleles I^A and I^B to have blood type A? Explain your answer. (Refer to Figure 14–5).

Think Critically

6. **Predict** What are the possible genotypes of the parents of a male child who is colorblind?
7. **Design an Experiment** Fruit fly sex is determined by X and Y chromosomes, just as it is in humans. Researchers suspect that a certain disease is caused by a recessive allele in a gene located on the X chromosome in fruit flies. Design an experiment to test this hypothesis.

14.2 Human Genetic Disorders

Understand Key Concepts

8. A mutation involving a change in a single DNA base pair
 - a. will definitely result in a genetic disease.
 - b. will have no effect on the organism's phenotype.
 - c. will produce a positive change.
 - d. may have an effect on the organism's phenotype.

9. Cystic fibrosis is caused by
 - a. nondisjunction of an autosome.
 - b. a change of three base pairs in DNA.
 - c. nondisjunction of a sex chromosome.
 - d. deletion of an entire gene from a chromosome.
10. Malaria is a disease caused by a
 - a. gene mutation.
 - b. defect in red blood cells.
 - c. bacterium found in water.
 - d. parasite carried by mosquitoes.
11. Analyze the human karyotype below. Identify the chromosomal disorder that it shows.

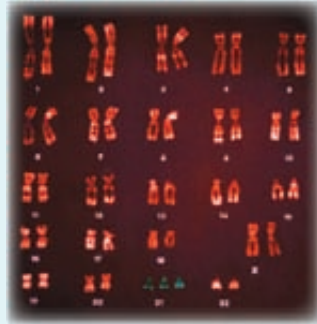

12. What is a chromosomal disorder?
13. Describe two sex-chromosome disorders.

Think Critically

14. **Infer** Can a genetic counselor use a karyotype to identify a carrier of cystic fibrosis? Explain.

15. **Interpret Graphs** What can you infer about the relationship between the age of the mother and the incidence of Down syndrome?

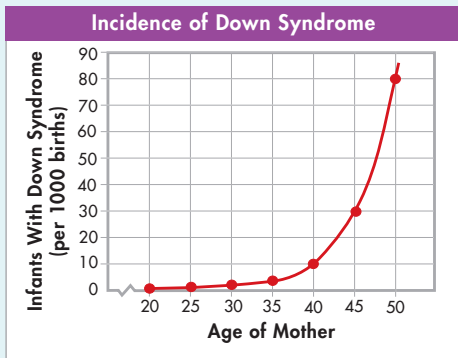

14.3 Studying the Human Genome

Understand Key Concepts

16. The human genome consists of approximately how many DNA base pairs?
- 30,000
 - 3,000,000
 - 300,000,000
 - 3,000,000,000
17. The fraction of the human genome that actually codes for proteins is about
- 2%
 - 20%
 - 98%
 - 100%
18. Cutting DNA into small pieces that can be sequenced is accomplished by
- restriction enzymes.
 - DNA polymerase.
 - gel electrophoresis.
 - RNA polymerase.
19. If you sequence short pieces of DNA and then use a computer to find overlapping sequences that map to a much longer DNA fragment, you are using
- genomics.
 - hapmaps.
 - shotgun sequencing.
 - open reading frame analysis.
20. Describe the tools and processes that scientists use to manipulate human DNA.
21. Explain why restriction enzymes are useful tools in sequencing DNA.

solve the CHAPTER MYSTERY

THE CROOKED CELL

When Ava inquired about her family's medical history, she found out that Uncle Eli's mother (Ava's grandmother) also had sickle cell disease, but Uncle Eli's father did not. One of her uncle's four children also had the disease. However, Ava's father, who is Eli's only sibling, did not have sickle cell disease, nor did Ava's mother. Ava's two siblings showed no signs of the disease, either.

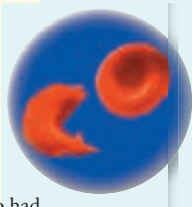

- Apply Concepts** In general, what pattern of heredity does the sickle cell trait follow? Cite evidence from the chapter and its clues to support your conclusion.
- Draw Conclusions** Based on your answer to question 1, what can you conclude about the inheritance of sickle cell disease in Ava's family? What might be Ava's chances of being a carrier of the sickle cell trait?
- Classify** What kind of medical test could Ava request that would help determine whether or not she has the sickle cell trait? Explain your answer.
- Infer** The restriction enzyme *MstII*, which cuts normal DNA at a particular site, will not recognize (and, therefore, will not cut) DNA that contains the sickle cell mutation. If Uncle Eli's DNA is cut with *MstII*, will the restriction fragments be identical to those from his brother, Ava's father? Explain.
- Focus on the Big Idea** Which technique(s) that you have read about in this chapter could be used to perform the kind of test described in question 4? Which technique could be used to analyze the results?

22. What is an SNP (single nucleotide polymorphism)?
 23. What is bioinformatics?

Think Critically

24. **Draw Conclusions** Scientists have searched the human genome database to find possible promoter sequences. What is likely to be found near a promoter sequence?
 25. **Infer** Why does DNA move toward the positive end of the gel during gel electrophoresis?
 26. **Observe** The table below shows the DNA sequences that are recognized by five different restriction enzymes and the locations where those enzymes cut. Which enzymes produce DNA fragments with “sticky ends”? What is the common feature of the sequences cut by these enzymes?

DNA Sequences Cut by Enzymes	
Enzyme	Recognition Sequence
<i>AluI</i>	A G ↓ C T T C ↑ G A
<i>HaeIII</i>	G G ↓ C C C C ↑ G G
<i>BamHI</i>	G ↓ G A T C C C C T A G ↑ G
<i>HindIII</i>	A ↓ A G C T T T T C G A ↑ A
<i>EcoRI</i>	G ↓ A A T T C C T T A A ↑ G

Connecting Concepts

Use Science Graphics

Use the data table to answer questions 27 and 28.

Chromosomes and Phenotypes		
Sex Chromosomes	Fruit Fly Phenotype	Human Phenotype
XX	Female	Female
XY	Male	Male
X	Male	Female
XXY	Female	Male

27. **Interpret Tables** What differs in the sex-determining mechanism of the two organisms?
 28. **Draw Conclusions** What can you logically conclude about the genes on the sex chromosomes of fruit flies and humans?

Write About Science

29. **Explanation** Write a paragraph that tells how colorblindness is inherited. Describe the condition and explain why it is much more common in males. (*Hint:* Begin your paragraph with a topic sentence that expresses the paragraph’s main idea.)
 30. **Assess the Big Idea** Explain the relationship between meiosis and Down syndrome, Turner’s syndrome, and Klinefelter’s syndrome.

Analyzing Data

Hemophilia is an example of a sex-linked disorder. Two genes carried on the X chromosome help control blood clotting. A recessive allele in either of these two genes may produce hemophilia. The pedigree shows the transmission of hemophilia through three generations of a family.

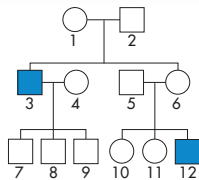

31. **Interpret Diagrams** Which mothers are definite carriers of the gene?
 32. **Apply Concepts** Why did the sons of Person 3 not inherit the trait?
 33. **Apply Concepts** How could Person 12 have hemophilia if neither of his parents had hemophilia?

Standardized Test Prep

Multiple Choice

- Which of the following disorders can be observed in a human karyotype?
 - colorblindness
 - trisomy 21
 - cystic fibrosis
 - sickle cell disease
- Which of the following disorders is a direct result of nondisjunction?
 - sickle cell disease
 - Turner's syndrome
 - Huntington's disease
 - cystic fibrosis
- A woman is homozygous for A⁻ blood type. A man has AB⁻ blood type. What is the probability that the couple's child will have type B⁻ blood?
 - 0%
 - 50%
 - 75%
 - 100%
- Cystic fibrosis is a genetic disorder caused by a
 - single base substitution in the gene for hemoglobin.
 - deletion of an amino acid from a chloride channel protein.
 - defective gene found on the X chromosome.
 - trisomy of chromosome 21.
- The technique used to separate DNA strands of different lengths is
 - gel electrophoresis.
 - shotgun sequencing.
 - restriction enzyme digestion.
 - bioinformatics.
- The study of whole genomes, including genes and their functions, is called
 - bioinformatics.
 - information science.
 - life science.
 - genomics.

- DNA can be cut into shorter sequences by proteins known as
 - haplotypes.
 - polymerases.
 - restriction enzymes.
 - restriction fragments.

Questions 8–9

A student traced the recurrence of a widow's peak hairline in her family. Based on her interviews and observations, she drew the pedigree shown below.

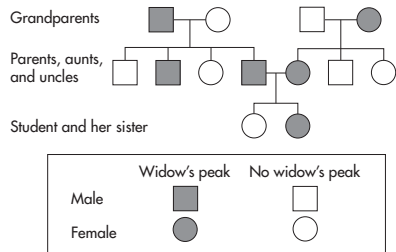

- Which pattern of inheritance is consistent with the pedigree?
 - sex-linked inheritance
 - complete dominance
 - codominance
 - multiple alleles
- What are the probable genotypes of the student's parents?
 - Mother— Ww ; Father— ww
 - Mother— ww ; Father— ww
 - Mother— WW ; Father— Ww
 - Mother— Ww ; Father— Ww

Open-Ended Response

- Explain how the gene for sickle cell disease, which is a harmful gene when it is homozygous, can be beneficial when it is heterozygous.

If You Have Trouble With . . .

Question	1	2	3	4	5	6	7	8	9	10
See Lesson	14.1	14.2	14.1	14.2	14.3	14.3	14.3	14.1	14.1	14.2